

Industrial RS-485/TTL 5V Converter



Part Number: TTL-485-2



■ INTRODUCTION

The TTL-485-2 is an industrial grade (wide temperature range with surge & static protection) port-powered bi-directional RS-485 to 5VDC TTL/COMS converter, which can be used to convert RS-485 to 5VDC TTL/COMS compatible levels and vice versa. The unit is powered from an external 5VDC power supply. It supports data direction auto-turnaround, and therefore, no flow control is required.

■ FEATURES

- Industrial grade with wide temperature range, surge and static protection.
- Plug and play (hot-pluggable, data format auto-sensing and self-adjusting).
- Data direction auto-turnaround, no flow control is required.
- Built-in surge protection, static protection and circuit protection.
- Built-in 120Ω end-of-line terminator for easy installation.
- Surface Mount Technology manufactured to ISO-9001 standards.
- CE certified.
- 5-year manufacturer's warranty.

■ SPECIFICATIONS

Compatibility:	EIA/TIA RS-485 standard and TTL/COMS 5VDC level
Power Source:	+5VDC (±5%) Regulated Power Supply (not included)
Current Consumption:	Less than 30mA
Baud Rates:	300 to 115,200bps (auto-sensing and self-adjusting)
Distance:	TTL side: 10ft (3m) RS-485 side: Up to 4000ft (1.2km) at 19,200bps;
Connectors:	TTL side: DB-9 Male; RS-485 side: DB-9 Male; Termination Board (TTL): DB-9 Female and a 3-way Terminal Block; Termination Board (RS-485): DB-9 Female and a 4-Way Terminal Block
Maximum number of drops:	128
End-of-Line Terminator:	120Ω (Built-in)
Surge Protection:	600W
Static Protection (ESD):	Up to 15KV
Dimensions (H x W x D):	0.63 x 1.3 x 4.5 in (16 x 32 x 115 mm) (with termination boards)
Weight:	1.66 oz (47 g) (with termination boards)
Operating Temperature:	-40°F to 185°F (-40°C to 85°C)
Operating Humidity:	Up to 90% RH (no condensation)

■ PIN ASSIGNMENT

TTL Side (DB-9 Male Connector / Terminal Block):

DB-9 Male Connector:	1	3	5
Terminal Block:	TX	RX	GND
Function:	TTL OUT	TTL IN	GND

RS-485 Side (DB-9 Male Connector / Terminal Block):

DB-9 Male Connector:	1	3	5	6,7	9
Terminal Block:	A+	B-	GND	Jumper (120)	+5V
Function:	RS485+	RS485-	GND	Terminate/remove Jumper 120 to turn ON/OFF the 120Ω end-of-line terminator	+5V input

Termination Boards:

TTL

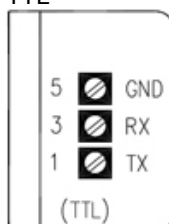

- Numbers on the left indicate the pin assignment of DB-9 Connectors (TTL side).
- TX is the TTL Output, RX is the TTL Input.

RS-485

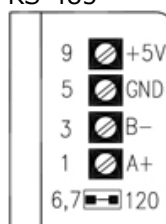

- Numbers on the left indicate the pin assignment of DB-9 Connectors (RS-485 side).
- Connect an external +5VDC regulated power supply to +5V and GND.
- Turn ON the 120Ω end-of-line terminator only when the RS-485's distance is over 660ft (200m).

■ CONNECTIONS

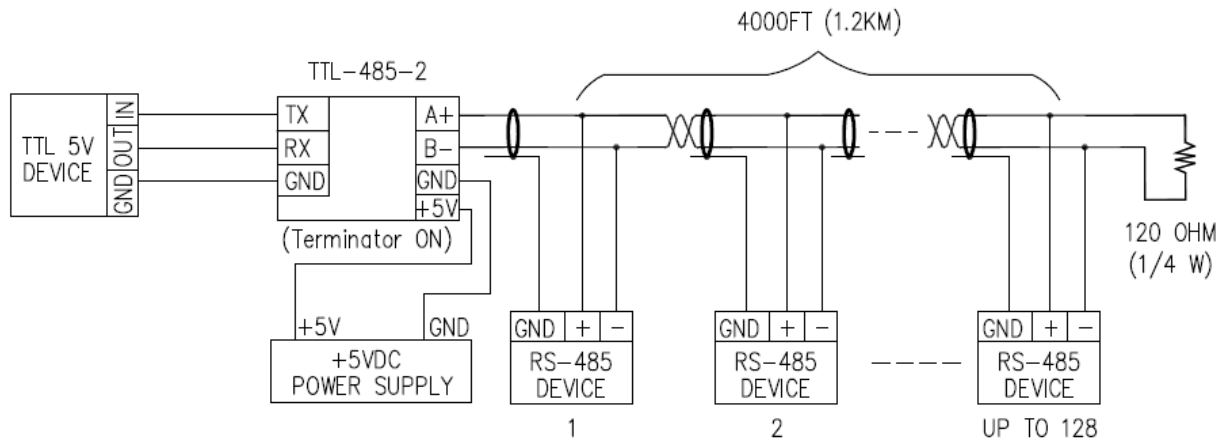

FIGURE 1: MASTER-SLAVE MULTI-DROP CONNECTIONS (RS-485)

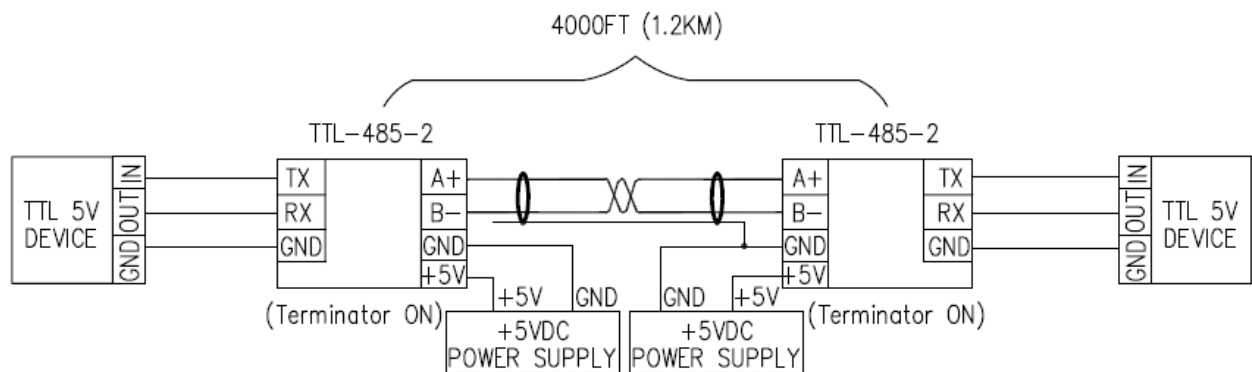

FIGURE 2: EXTENDING TTL DISTANCE (HALF-DUPLEX)

■ INSTALLATION NOTES

- **CAUTION:** Be sure that the DC power applied to pin +5V and GND is within the range of +4.75V to +5.25V (5V \pm 5%). Excessive input voltage or incorrect polarity connection could damage the converter.
- The 120 Ω end-of-line terminator adds heavy DC loading to a system; connect it only when the RS-485's distance is over 660ft (200m).
- If TTL-485-2 is connected to any outdoor devices, please ensure that proper lightning protection is employed to prevent your devices from being damaged by lightning strikes.

■ TTL SIGNAL LEVELS

TTL Input	TTL Output
High (>2.0V)	High (>3.5V)
Low (<0.8V)	Low (<0.6V)

■ TROUBLESHOOTING

- Measure pin +5V and GND with a Voltmeter, and be sure that it is within the range of +4.75V to +5.25V (5V \pm 5%). Excessive input voltage or incorrect polarity connection could damage the converter.
- Perform a loopback test by using CommFront's 232Analyzer software: Connect two numbers of TTL-485-2 to your PC's RS-485 COM ports and connect the TTL terminals with a crossover cable (TX to RX and RX to TX), then run two instances of the 232Analyzer software and send commands from one COM port, you should receive an echo of the commands sent on the other COM port (Note: You will need a RS-232 to RS-485 converter if there is no RS-485 port on your PC). You should receive an echo of the commands sent. By performing a simple loopback test like this, you can test both the transmitter and receiver of the RS-485/TTL converter. This is very helpful when you are in doubt about the performance of your converter.