

Industrial RS-232/RS-485 Converter



Part Number: CVT-485-1



Communications made easy

■ INTRODUCTION

The CVT-485-1 is an industrial grade (wide temperature range with surge & static protection) port-powered bi-directional RS-232 to RS-485 converter, which can be used to convert any standard RS-232C port into a two-wire RS-485 port and vice versa. The unit is powered from the RS-232 data line; it also supports data direction auto-turnaround. Therefore, no external power or flow control is required.

■ FEATURES

- Industrial grade with wide temperature range, surge and static protection.
- Port-powered, no external power or RTS, DTR required.
- Plug and play (hot-pluggable, data format auto-sensing and self-adjusting).
- Data direction auto-turnaround, no flow control is required.
- Built-in surge protection, static protection and circuit protection.
- Built-in 120Ω end-of-line terminator for easy installation.
- Surface Mount Technology manufactured to ISO-9001 standards.
- CE certified.
- 5-year manufacturer's warranty.

■ SPECIFICATIONS

Compatibility:	EIA/TIA RS-232C standard and RS-485 standard
Power Source:	Port power from RS-232 data line
Current Consumption:	Less than 10mA
Baud Rates:	300 to 115,200bps (auto-sensing and self-adjusting)
Distance:	RS-232 side: 16ft (5m); RS-485 side: Depending on power from RS-232 port, will transmit up to 4000ft (1.2km) at 19,200bps
Connector:	RS-232 side: DB-9 Female; RS-485 side: DB-9 Male; Termination Board: DB-9 Female and a 4-Way Terminal Block
Maximum number of drops:	128
End-of-Line Terminator:	120Ω (Built-in)
Surge Protection:	600W
Static Protection (ESD):	Up to 15KV
Dimensions (H x W x D):	0.63 x 1.3 x 3.4 in (16 x 32 x 86 mm) (with termination board)
Weight:	1.27 oz (36 g) (with termination board)
Operating Temperature:	-40°F to 185°F (-40°C to 85°C)
Operating Humidity:	Up to 90% RH (no condensation)

■ PIN ASSIGNMENT

RS-232 Side (DB-9 Female Connector):

DB-9 Pin:	1	4	6	7	8	2	3	5
Function/Internal Wiring:	tied together			tied together		TX	RX	GND

RS-485 Side (DB-9 Male Connector / Terminal Block):

DB-9 Pin:	1	3	5	9	6,7
Terminal Block:	A+	B-	GND	+5V	Jumper (120)
Function:	RS485+	RS485-	GND	+5V measurement	Terminate/remove Jumper 120 to turn ON/OFF the 120Ω end-of-line terminator

Termination Board:

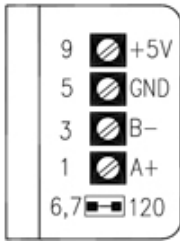

- The numbers on the left indicate the pin assignment of DB-9 male connector (RS-485 side).
- DO NOT connect external power to the +5V pin, it is for measurement only. The unit will function correctly only when the voltage on +5V pin is around +5V (when RS-232 port is connected). Otherwise, please check the connection.
- The unit comes with a built-in 120Ω end-of-line terminator; use it (Jumper ON) only when the distance is over 660ft (200m).

CONNECTIONS

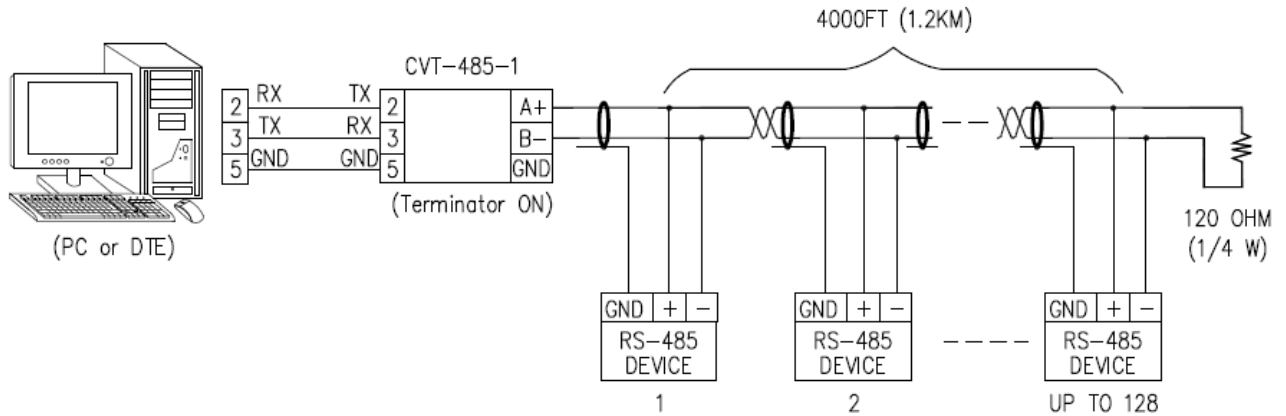

FIGURE 1: MASTER-SLAVE MULTI-DROP CONNECTIONS

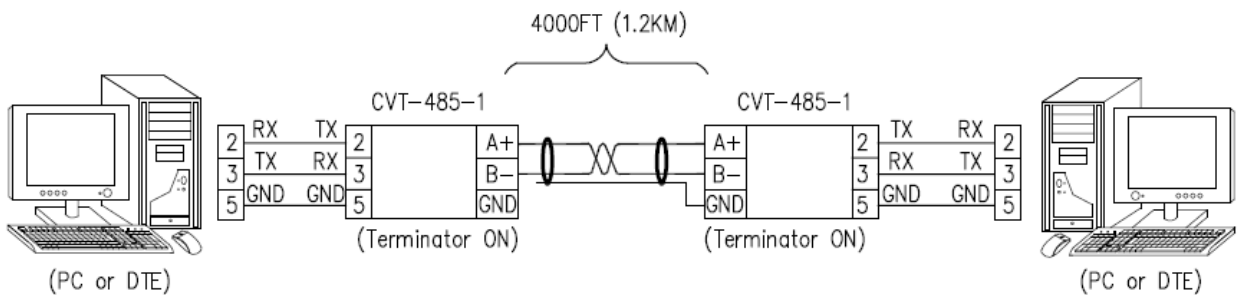

FIGURE 2: EXTENDING HALF-DUPLEX RS-232 DISTANCE (DATA ONLY)

INSTALLATION NOTES

- Connect PC's (or other DTE device's) COM port (or use a straight-through cable) to the RS-232 side of CVT-485-1, use a cross-over (Null-Modem) cable for DCE device.
- The 120Ω end-of-line terminator adds heavy DC loading to a system; connect it only when the RS-485's distance is over 660ft (200m).
- If CVT-485-1 is connected to any outdoor devices, please ensure that proper lightning protection is employed to prevent your devices from being damaged by lightning strikes.

TROUBLESHOOTING

- Measure pin +5V and GND with a voltmeter, and be sure that it is around +5VDC (when RS-232 port is connected). Otherwise, please check the connection.
- Perform a loopback test by using CommFront's 232Analyzer software: Connect two numbers of CVT-485-1 to your PC's COM ports and run two instances of the 232Analyzer software, then send commands from one COM port, you should receive an echo of the commands sent on the other COM port. By performing a simple loopback test like this, you can test both the transmitter and receiver of the converter. This is very helpful when you are in doubt about the performance of your converter.